

ITEM	Location	-	
	Service	-	
	Equip No.	-	
	Fan Model	DR-FH30FTC	
F A N		MOTOR (60Hz)	
AIR VOLUME	-	m ³ /min	POWER 3.46 Kw
STATIC PRESSURE	SUC -	mmAq	VOLTAGE 380 V
	DIS -	mmAq	PHASE 3 Ph
OPERATING FLUID	AIR (At)20°C		POLSE 4 P
REVOLUTION	1710 R.P.M		REVOLUTION 1710 R.P.M
BEARING	in side	-	PULLEY fan - ty- p - "
	out side	-	
COLOR	casing	-	
	belt cover	-	
QUANTITY	-	EA	V-VELT LENGTH - "

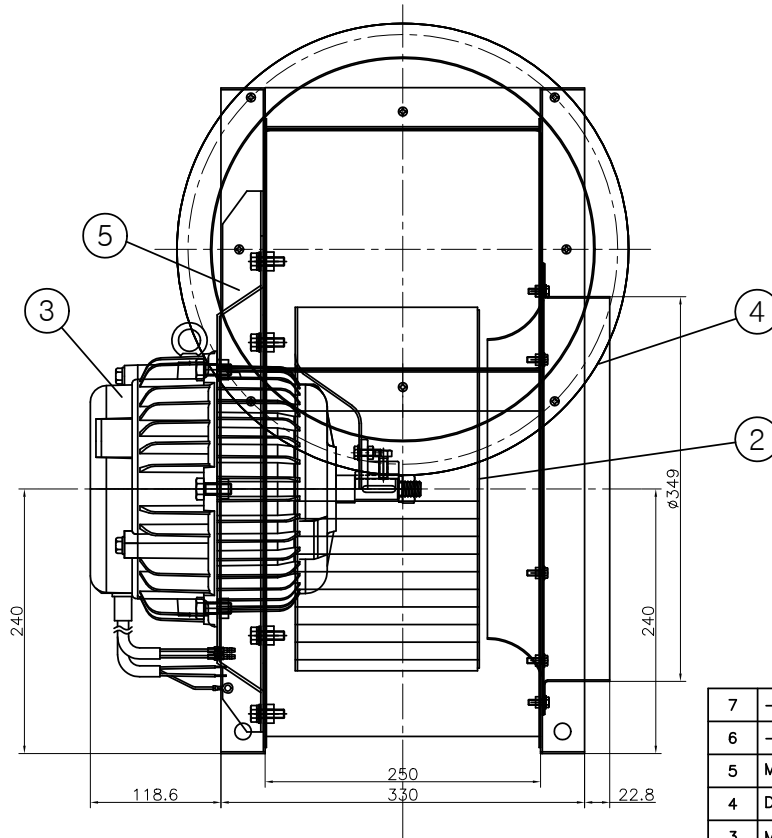
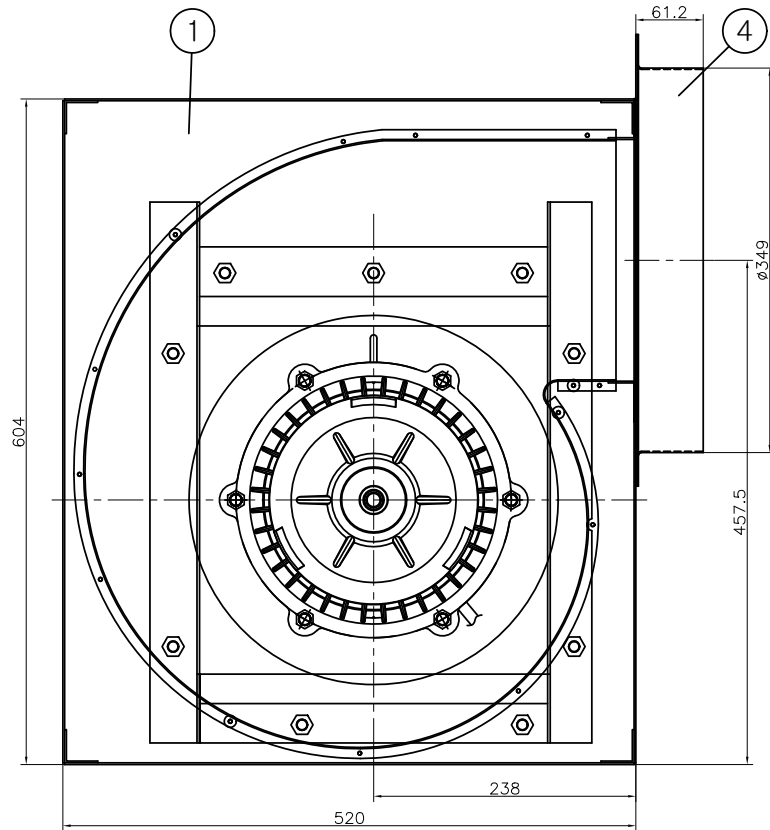

7	-	-	-	-	
6	-	-	-	-	
5	Motor Support	SPCC	1		
4	Duct Flange	SPCC	2		
3	Motor		1		
2	Impeller	SPCC	1		
1	Casing	SPCC	1		
ITEM NO.	NOMENCLATURE	MATERIAL	SIZE	QUAN'T	REMARK

		대륜산업(주)		High Static Pressure Sirocco Fan	
SCALE	N/S	DWG. BY	DES'N BY	CH'D BY	APPROVE
UNIT	mm	K.G.L			
NO.	DATE	REVISION & DESCRIPTION	REVIEWED	CHECKED	DWG DATE : 2016.06.16
					PROJECT -
					CUSTOMER -
					DWG CODE -