

ITEM	Location	-	
	Service	-	
	Equip No.	-	
	Fan Model	DR-F35HTC	
F A N		MOTOR (60Hz)	
AIR VOLUME	-	m ³ /min	POWER 5.5 Kw
STATIC PRESSURE	SUC -	mmAq	VOLTAGE 380 V
	DIS -	mmAq	PHASE 3 Ph
OPERATING FLUID AIR	(At)20°C		POLSE 4 P
REVOLUTION	1730	R.P.M	REVOLUTION 1730 R.P.M
BEARING	in side	-	PULLEY fan -ty -p -"
	out side	-	
COLOR	casing	-	
	belt cover	-	
QUANTITY	-	EA	V-VELT LENGTH - "

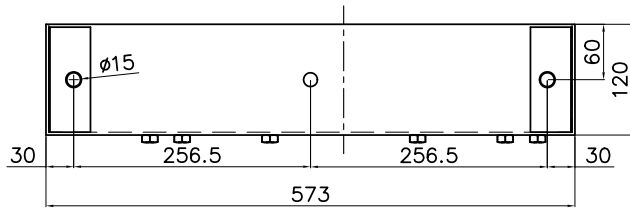
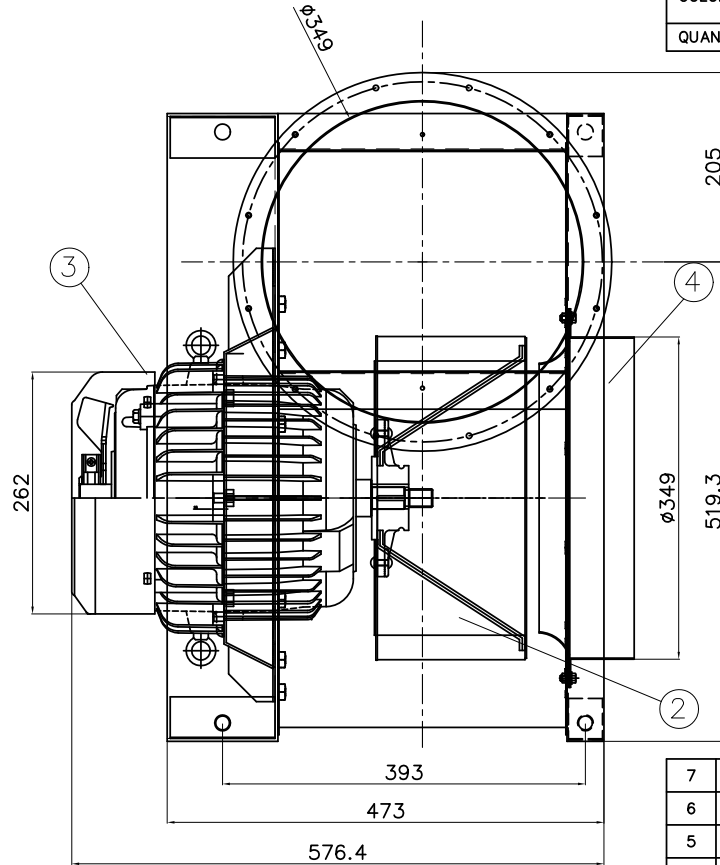
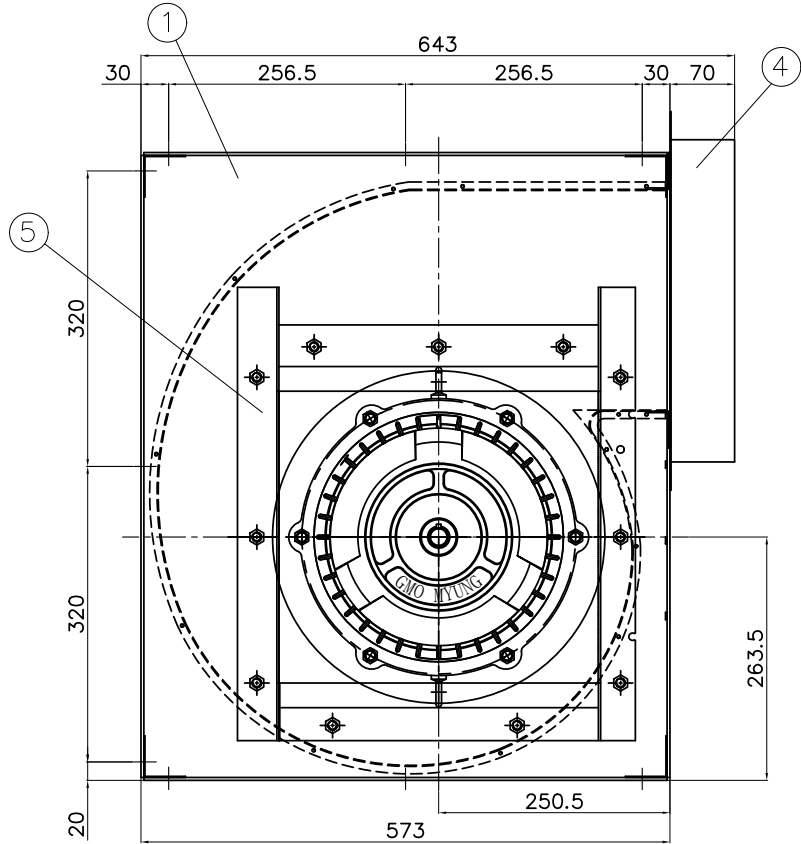

7	-	-	-	-	-
6	-	-	-	-	-
5	Motor Support	SS400		1	
4	Duct Flange	SPCC		2	
3	Motor			1	
2	Impeller	SPCC		1	
1	Casing	SPCC		1	
ITEM NO.	NOMENCLATURE	MATERIAL	SIZE	QUAN'T	REMARK

		대륜산업(주)		Large Sirocco Fan	
SCALE	N/S	DWG. BY	DES'N BY	CH'D BY	APPROVE
UNIT	mm	K.O.M			
NO.	DATE	REVISION & DESCRIPTION	REVIEWED	CHECKED	DWG DATE : 2020.03.18
					PROJECT -
					CUSTOMER -
					DWG CODE -