

ITEM	Location	-	
	Service	-	
	Equip No.	-	
	Fan Model	DR-FIL500TC	
F A N		MOTOR (60 Hz)	
AIR VOLUME	-	m ³ /min	POWER 1.3 Kw
STATIC PRESSURE	SUC -	mmAq	VOLTAGE 380 V
	DIS -	mmAq	PHASE 3 Ph
OPERATING FLUID AIR	(At)20°C		POLSE 4 P
REVOLUTION	1740	R.P.M	REVOLUTION 1740 R.P.M
BEARING	in side	-	PULLEY fan -ty -p -"
	out side	-	
COLOR	casing	GRAY	
	belt cover	-	
QUANTITY	-	EA	V-VELT LENGTH - "

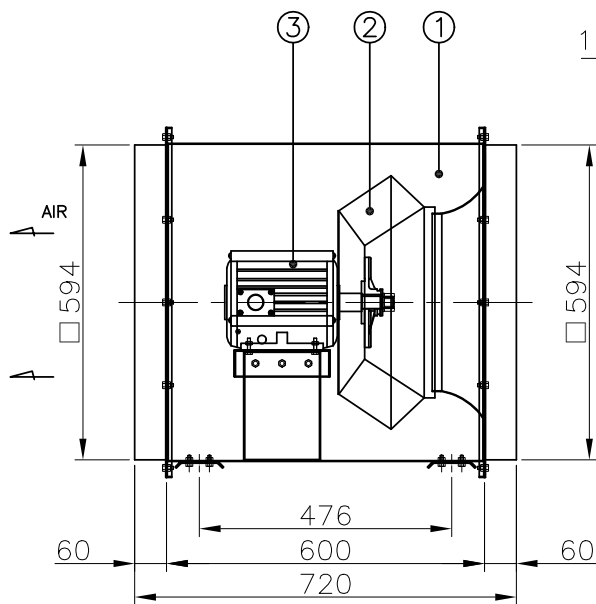

16-M8 Bolt/Nut

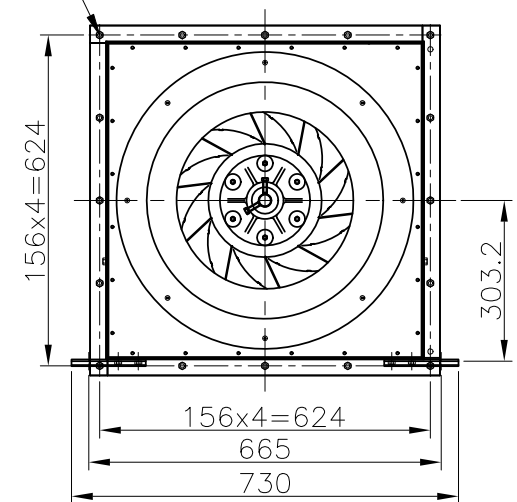

7	-	-	-	-	-
6	-	-	-	-	-
5	-	-	-	-	-
4	-	-	-	-	-
3	Motor			1	
2	Impeller	SPCC		1	
1	Casing	SPCC		1	
ITEM NO.	NOMENCLATURE	MATERIAL	SIZE	QUAN'T	REMARK

		대륜산업(주)		DUCT IN LINE FAN	
SCALE	N/S	DWG. BY	DES'N BY	CH'D BY	APPROVE
UNIT	mm				
NO.	DATE	REVISION & DESCRIPTION	REVIEWED	CHECKED	DWG DATE : 2019.09.18
					CUSTOMER -
					DWG CODE -