

DETAIL A

ITEM	Location	-	
	Service	-	
	Equip No.	-	
	Fan Model	DR-GIL550TP	
F A N		MOTOR (60 Hz)	
AIR VOLUME	-	m ³ /min	POWER 0.75 Kw
STATIC	SUC	- mmAq	VOLTAGE 380 V
PRESSURE	DIS	- mmAq	PHASE 3 Ph
OPERATING FLUID AIR (At)20°C		POLSE 6 P	
REVOLUTION 1150 R.P.M		REVOLUTION 1150 R.P.M	
BEARING	in side	-	PULLEY fan - ty - p - "
	out side	-	
COLOR	casing	-	
	belt cover	-	
QUANTITY	-	EA	V-VELT LENGTH - "

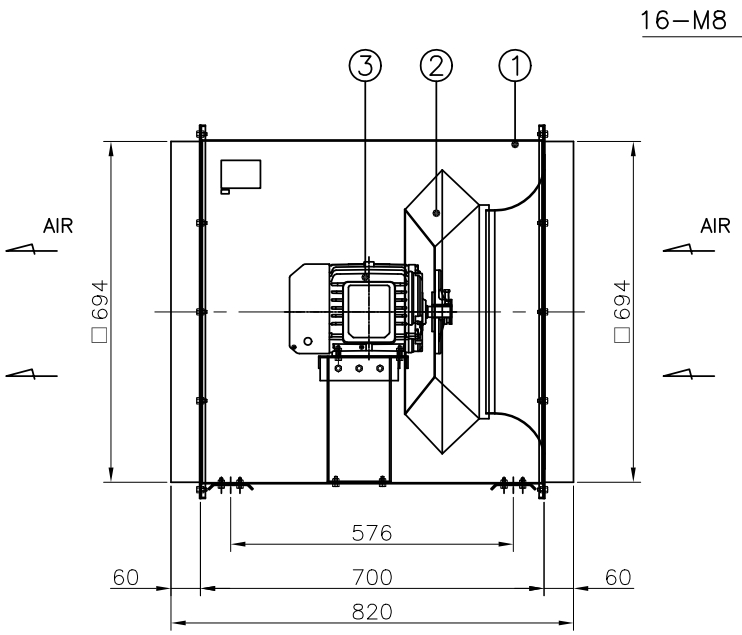

16-M8 Bolt/Nut

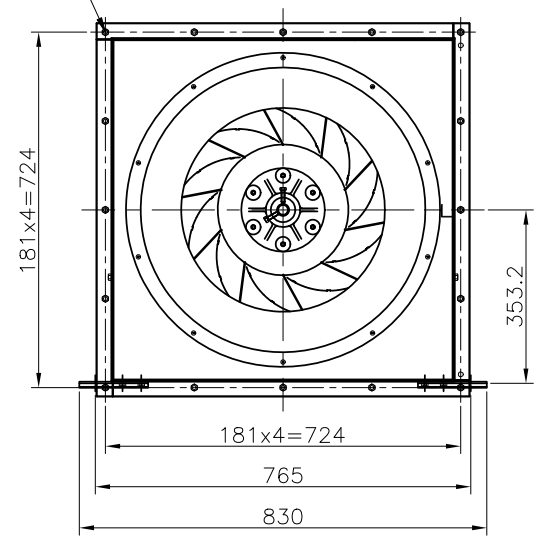

7	-	-	-	-	-
6	-	-	-	-	-
5	-	-	-	-	-
4	-	-	-	-	-
3	Motor		1Hp	1	
2	Impeller	SPCC		1	
1	Casing	SPCC		1	
ITEM NO.	NOMENCLATURE	MATERIAL	SIZE	QUAN'T	REMARK

		대륜 산업 (주)		DUCT IN LINE FAN	
SCALE	DWG. BY	DES'N BY	CH'D BY	APPROVE	PROJECT
N/S					-
UNIT					CUSTOMER
mm					-
NO.	DATE	REVISION & DESCRIPTION	REVIEWED	CHECKED	DWG CODE
					-

SCALE N/S UNIT mm
DWG DATE : 2019.08.27