

DETAIL A

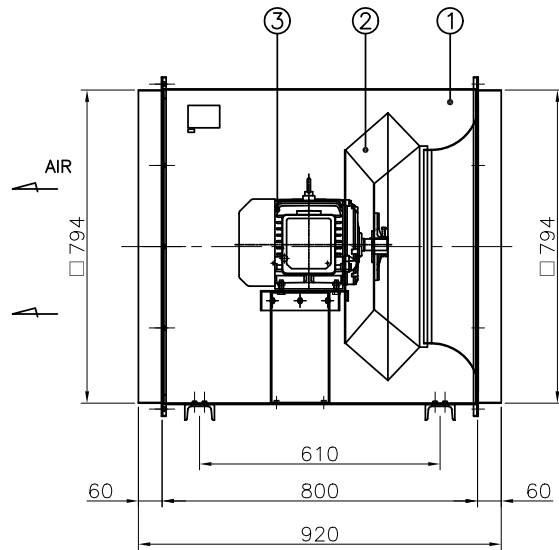

16-M8 Bolt/Nut

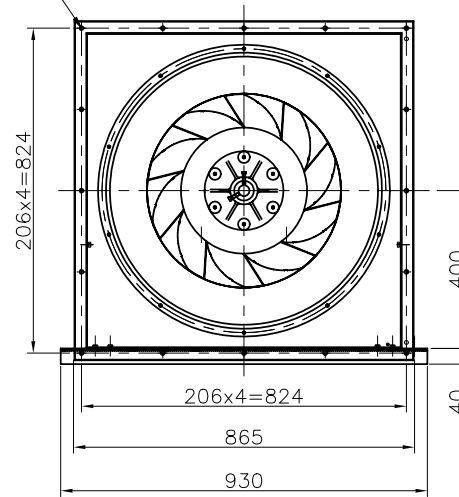

ITEM	Location	-	
	Service	-	
	Equip No.	-	
	Fan Model	DR-GIL650TP	
F A N		MOTOR (60 Hz)	
AIR VOLUME	-	m ³ /min	POWER 2.2 Kw
STATIC	SUC	- mmAq	VOLTAGE 380 V
PRESSURE	DIS	- mmAq	PHASE 3 Ph
OPERATING FLUID AIR	(At)20°C		POLSE 6 P
REVOLUTION	1170	R.P.M	REVOLUTION 1170 R.P.M
BEARING	in side	-	PULLEY fan - ty - p - "
	out side	-	
COLOR	casing	-	
	belt cover	-	
QUANTITY	-	EA	V-VELT LENGTH - "

7	-	-	-	-	-
6	-	-	-	-	-
5	-	-	-	-	-
4	-	-	-	-	-
3	Motor		3Hp	1	
2	Impeller	SPCC		1	
1	Casing	SPCC		1	
ITEM NO.	NOMENCLATURE	MATERIAL	SIZE	QUAN'T	REMARK

SCALE		대륜산업(주)		DUCT IN LINE FAN	
N/S	DWG. BY	DES'N BY	CH'D BY	APPROVE	PROJECT
UNIT	-	-	-	-	CUSTOMER
mm	-	-	-	-	DWG CODE
NO.	DATE	REVISION & DESCRIPTION	REVIEWED	CHECKED	DWG DATE : 2019.08.29